







Oil supply unit OSU

Compact unit for reliable oil filtration, cooling and supply

MULTIPLE DESIGN OPTIONS WITH OIL COOLER, OIL HEATER, FILTERS, VALVES AND SENSORS



-  Mineral and synthetic oils 20 to 1 000 mm²/s
-  up to 60 bar (145 psi)
-  10 to 40 °C (50 to 104 °F)
-  0.1 to 19 l/min (0.02 to 5 gal/min)
-  15 to 200 l (3.9 to 52 gal)
-  Digital control and monitoring options



Applications

- Mineral processing, mining
- Metals and heavy industry
- Food and beverage
- Printing & textile
- Pulp&paper
- Automotive
- Cement
- Energy

Sustainability, productivity and digitalization



OSU – a sustainable solution

Oil circulation lubrication systems are increasingly being recognized for their sustainability benefits in industrial applications. These systems minimize friction and heat on machinery by continuously supplying lubricant, which leads to a significant reduction in energy consumption. By optimizing the amount of lubricant used and ensuring it is delivered precisely where needed, they reduce waste and environmental impact. Moreover, the extended life of both the lubricant and equipment due to efficient lubrication practices contributes to resource conservation and lower maintenance costs, making oil circulation systems a sustainable choice.

- Reduced oil purchase and disposal volume
- Reduced machine wear and spares
- Reduced energy consumption
- Extended oil service life



OSU - increases productivity

Oil circulation lubrication systems are essential for the efficient operation of various machinery. These instruments and interfaces enable an easy interaction with machinery or mill control system. System will continuously supply lubricant to critical machine components such as bearings and gearboxes ensuring that it serves to remove heat and contaminants from these components. This is crucial for maintaining optimal machine performance. By providing a steady flow of oil, these systems help to prevent overheating and reduce the risk of mechanical failures. That leads to enhanced productivity and supports the most reliable machine operation.



OSU - enables digitalization

OSU is characterized by advanced digitization features that enable comprehensive and efficient monitoring of oil circulation systems. Thanks to a large number of sensors that monitor the reservoir filling level, oil pressure, temperature, filter cleanliness and flow rates, OSU offers a rich database. This data enables the oil circulation unit to be optimally controlled and adjusted in real-time and allows users not only to precisely monitor the operating status of their machines, but also to pro-actively plan maintenance work and minimize downtime. These digitization features and digital interfaces allows an easy integration into existing digital machine and master control systems.

Product information

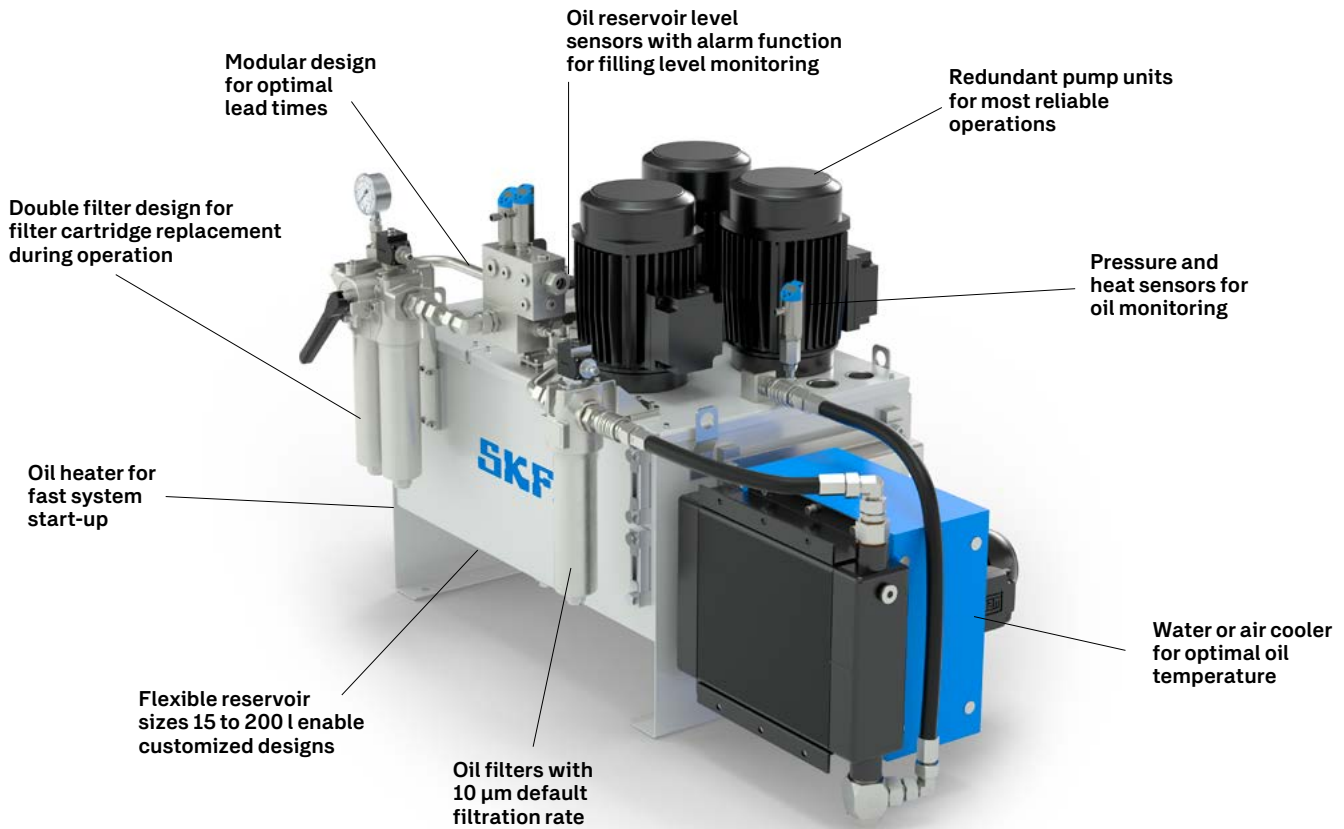

Description

OSU (Oil Supply Unit) is a compact oil circulation unit with various reservoir sizes from 15 to 200 liters that supply oil to machines that require a total flow of 0.1 to 19 l/min. The system pressure is adjusted by pressure control valves. The reservoirs can be equipped with heaters to control oil viscosity at start-up. Optional water or air coolers lower the temperature of the filtered oil to the desired level. Single or double filters with a default filtration rate of 10 µm care for reliable operations. OSU works reliable with SKF flow meters or flow limiters. In addition, the unit offers several monitoring options such as level, temperature and pressure sensors. The modular design corresponds to the building block principle and allows quick and easy design of standardized or customized solutions at short lead times.

Features and benefits

- Reliable oil condition and oil supply
- Extending oil and machine life with optimized cooling and lubrication
- Uncomplicated modular design
- System pressures up to 60 bar
- Designed for 24/7 operation
- Market proven solution

Technical data

Function	electrically operated oil supply unit
Lubricant	lubrication and hydraulic oils; 20 to 1 000 mm ² /s
Flow rate	0.1 to 19 l/min; 0.02 to 5 gal/min
Number of outlets ¹⁾	1–6
Ambient temperature	+10 to 40 °C; +50 to 104 °F
Oil temperature	+25 to 65 °C; +77 to 149 °F
Operating pressure max.	60 bar; max. 145 psi
Operating press. nominal	10, 16, 32 bar; 145, 232 and 464 psi
Reservoir	15, 30, 50, 100, 150 and 200 l 3.9; 7.9; 13; 26; 39 or 52 gal
Reservoir material	carbon steel, painted
Thermostat controlled	20 to 50 °C in 6 h;
Heater for oil tank	0.6 – 2.4 kW
Oil filtering rate	10 µm
Voltage	220–480 V AC, 50/60Hz
1GD	230/400 V AC 50 Hz;
	265/460 V AC 60 Hz
1GP	220/380 V AC 50 Hz;
	255/440 V AC 60 Hz
1GQ	240/415 V AC 50 Hz;
	280/480 V AC 60 Hz
Pressure connection	G / NPT 1/2; G / NPT 1; G / NPT 1 1/4
Protection class	IP 54
Dimensions	min. 500 × 300 × 600 mm min. 19.6 × 18.8 × 23.6 in max. 1 500 × 700 × 1 100 mm max. 59 × 27.5 × 43.3 in
Mounting position	upright

¹⁾ SKF flow meters or flow limiters have to be ordered separately.

Installation information

Installation drawing

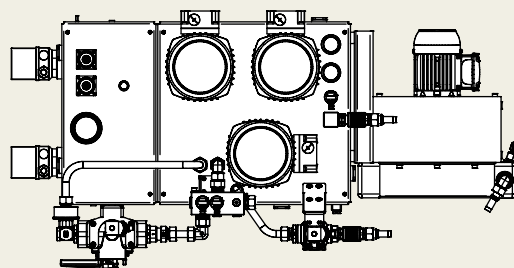
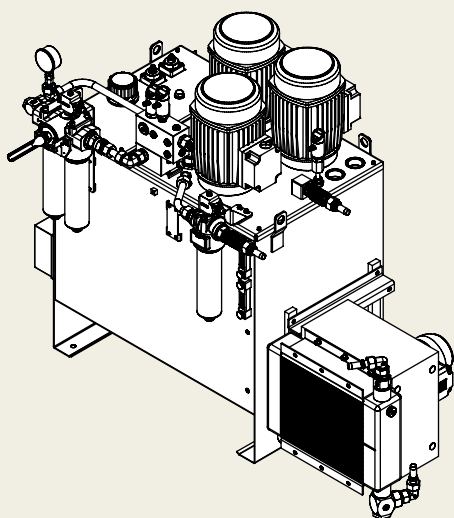
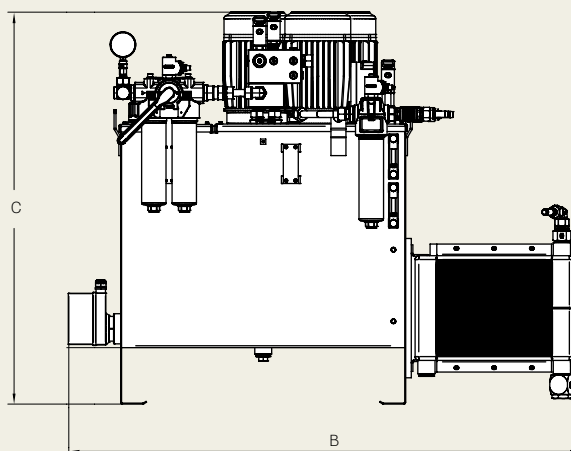
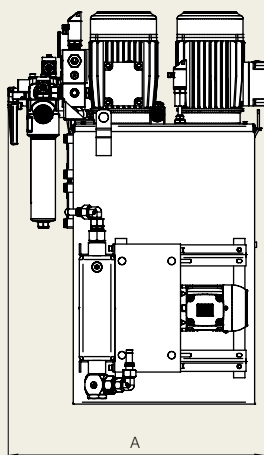

Installation dimensions

Design	Reservoir size		Dimensions min.			Dimensions max.		
	l	gal	A	B	C	A	B	C
			mm	mm	mm	mm	mm	mm
OSU1-...-A-...-...-...	15	3.9	500	300	600	630	450	650
OSU1-...-B-...-...-...	30	7.9	500	300	700	630	450	770
OSU1-...-C-...-...-...	50	13	500	300	900	700	450	970
OSU1-...-D-...-...-...	100	26	800	700	800	1500	700	800
OSU1-...-E-...-...-...	150	39	800	700	1500	1500	700	950
OSU1-...-F-...-...-...	200	52	800	700	1500	1500	700	1100
Frame	-	-	1050	700	1540	-	-	-

Order information

Order information standard versions

Designation ¹⁾	Flow rate		Reservoir size		Pumps & filters ³⁾	Filter alarms/ type	Pressure monitoring	Metering device bracket	Level alarms/ type	Heating capacity	Cooler	Cooling capacity
	l/min	pts/min	l	gal	amt.					kW		kW
OSU1-05S2-A1AA-9ZX3-1GD	0.50	1.0	15	3.9	1	visual	–	–	–	–	–	–
OSU1-1XS1-B1AC-9XX3-1GD	1.20	2.5	30	7.9	1	2/M12	sensor	–	2/M12	0.6	–	–
OSU1-2XS1-C5CB-1XX1-1GD	2.50	5.2	50	13.2	1	2/M12	gauge	●	2/M12	0.6	–	–
OSU1-5XS1-C3AB-1CX1-1GD	5.25	11.0	50	13.2	1	1/DIN	gauge	●	2/DIN	0.6	water	3
OSU1-5XR1-D4AC-2CX3-1GD	5.25	11.0	100	26.4	2	1/DIN	sensor	–	2/DIN	1.2	water	8
OSU1-5XS1-D5EC-3BX1-1GD	5.25	11.0	100	26.4	1	2/M12	sensor	●	UT/M12	2.4	air	6
OSU1-9XS1-D3AC-8DX3-1GD	9.00	19.0	100	26.4	1	1/DIN	sensor	–	2/DIN	2.4	air	6
OSU1-9XR1-D6DC-3BX3-1GD	9.00	19.0	100	26.4	2	2/M12	sensor	–	3/M12	2.4	air	10
OSU1-12S1-E5CC-3BY1-1GD	12.50	26.4	150	39.6	1	2/M12	sensor	●	2/M12	2.4	air	10
OSU1-19R1-F4BC-2DX3-1GD	19.00	40.1	200	79.2	2	1/DIN	sensor	–	3/DIN	1.2	air	11.5

¹⁾ Order numbers available on request.

²⁾ Nominal flow rates at oil viscosity of 140 mm²/s and 5 bar system pressure.

Components for customized configurations - to be designed by SKF application engineering

Pump sizes	0.1 l/min 0.2 l/min 0.5 l/min	1.2 l/min 2.5 l/min 5.25 l/min	9 l/min 12.5 l/min 19 l/min
Number of pumps	single pump	secondary backup pump included	
Compliance	CE	CE+UL/CSA	CCC
Reservoir size	15 l 30 l	50 l 100 l	150 l 200 l
Filter	single filter with indicator double filter with indicator	single filter with DIN plug double filter with DIN plug	single filter with 2 alarm points (M12 plug) double filter with 2 alarm points (M12 plug)
Level switch	MIN level+pre-warning with DIN plug MIN level+pre-warning+MAX level with DIN plug MIN level+pre-warning with M12 plug		MIN+ MAX level+pre-warning with M12 plug Ultrasonic sensor+IO-Link+mA with M12 plug
Pressure monitoring	without	with pressure gauge	with pressure sensor with mA/switch/IO-link
Heating	0.6 kW (15, 30, 50 L reservoirs) 1.2 kW 2.4 kW	without heater but with temperature sensor without heater and without temp. sensor	
Cooling	water cooler in the bypass oil-air cooler in the bypass oil-water cooler in the pressure line ⁴⁾	oil-air cooler in the pressure line without cooler but with temperature sensor without cooler and without temperature sensor	
Control	without control and without terminal box		with terminal box
Back plate	back plate for flow limiters or flow meters		
Motor voltage	230 / 400 V 50 Hz+265/460 V 60 Hz 220 / 380 V 50 Hz+255/440 V 60 Hz		240 / 415 V 50 Hz + 280 / 480 V 60Hz 220 / 380 V 50 Hz

OSU design options



Control, terminal boxes and power supply

Pre-wired and tested stand-alone control ST-2240-CIRC or OAC controller with process control interface will enable easy start-up. Power supply unit with integrated VDF's will ensure stable pressure and save energy. In addition also simple terminal box design versions prepared for the integration into machine PLC are available.



Oil filling level monitoring

Fill level switches for oil containers with multiple switching points allow precise detection of the current fill level and warn the operator in good time when critical fill levels are exceeded. This enables also trending and early noticing in case of oil leakages.



Extra heating elements

Especially plate heat exchangers with water in oil circulation systems play a crucial role during the start-up phase of machines. They ensure that the oil is quickly brought to the required operating temperature, which is particularly important in cold ambient temperatures. This prevents the formation of condensate and the associated corrosion in the system. They also reduce the viscosity of the oil, which enables the machine to operate smoothly and with reduced wear and extends the service life of the components. Preheating the oil also increases the efficiency of the overall system, as the machine can reach its full performance more quickly.

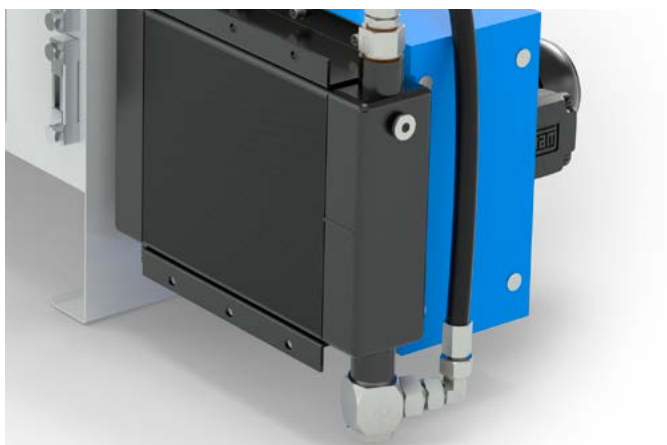

Oil cooler

Oil coolers in oil circulation systems offer numerous advantages that are essential for the efficient operation of machines and systems. Especially water based coolers help to maintain the optimal oil temperature, which reduces the susceptibility to downtime and increases the performance of the systems. The use of oil coolers minimizes the risk of overheating and associated damage such as the destruction of seals or other components. For OSU water and air coolers are available. Both cooling systems ensure heat dissipation and contribute to the longevity and reliability of the oil lubrication system.

OSU design options



Filtration and filter alarms

Single or double filters with a default filtration rate of 10 µm care for reliable operations. Filters in oil circulation systems are essential to ensure reliable operation of the system as well as machine lubricated. Filters remove dirt, metal chips, deposits and other contaminants from the oil circuit, which reduces oil aging and minimizes machine wear. Therefore, filter change after clogging signal is essential to ensure trouble free machine operation.



Pressure and temperature sensors

Electronic pressure and temperature sensors have an integrated digital display for relative measurement. Depending on the design, they can also trigger control functions, like warnings and alarms as programmed. Sensor includes IO-link for easy troubleshooting and communication with control systems.



Flow measurement

SKF offers wide range of flow meter and flow limiters to have precise oil flow for lubrication points. Range includes SMD, SMB, SM, FL, PSG and 242 families each having unique application range. Oil pressure, adjustment range and connectivity needed will be key parameters for product selection along with user preferences. OSU unit can be ordered with back-plate to accommodate metering devices up to 20 lubrication points. Real time oil flow measuring with local interface and remote connectivity through fieldbus is often the preferred choice of process industry customers. For less demanding applications visual indication with switch type alarms are often the best choice.



Pulse meters

IPM is a digital pulse meter to monitor oil circulation system metering devices like restrictor valves, flow limiters or progressive metering devices. The intuitive IPM touch display allows the entering of specified values for up to 45 lubrication points. Each point is monitored individually with indicating options in the event of malfunctions or alarms. In addition, IPM offers individual data connection inlet per lubrication point and five relay outputs that allow up to 15 different alarm combinations. Thanks to its modular design and its dynamic functionality, IPM can easily be adapted to changing machine and system requirements at any time.

skf.com | skf.com/osu | skf.com/lubrication

® SKF, LINCOLN and RECONDOIL are registered trademarks of AB SKF (publ).

© SKF Group 2025. All rights reserved. Please note that this publication may not be copied or distributed, in whole or in part, unless prior written permission is granted.

Every care has been taken to ensure the accuracy of the information contained in this publication, but no liability can be accepted for any loss or damage whether direct, indirect or consequential arising out of the use of the information contained herein.

PUB LS/P2 19924 EN · June 2025

Certain image(s) used under license from Shutterstock.com.

